

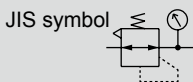

Precision regulator

RP1000 Series

● Port size: Rc1/4



Specifications

1 MPa = 10 bar

Descriptions	RP1000-8-02	RP1000-8-04	RP1000-8-07
Working fluid	Compressed clean air (refer to recommended air circuit on page 453)		
Max. working pressure	MPa	1.0 (≈150 psi, 10 bar)	
Min. working pressure	MPa	Set pressure +0.1 (≈15 psi, 1 bar) *1	
Proof pressure	MPa	1.5 (≈220 psi, 15 bar)	
Ambient / fluid temperatures	°C	-5 (23°F) to 60 (140°F) (no freezing) *3	
Set pressure	MPa	0.003 (≈0.44 psi) to 0.2 (≈29 psi)	0.005 (≈0.73 psi) to 0.4 (≈58 psi) 0.005 (≈0.73 psi) to 0.7 (≈100 psi)
Sensitivity		Within 0.1% of full scale	
Repeatability		Within ±0.5% of full scale	
Air consumption *2	ℓ/min(ANR)	1.3 or less	3.4 or less
Port size		Rc1/4	
Pressure gauge port size		Rc1/8	
Weight	g	250	

*1: Flow rate of the secondary side is to be zero. For RP1000-8-04, if the set pressure is 0.3 MPa and over, increase +0.2 MPa in the set pressure.

*2: Conditions where the primary pressure is 0.7 MPa. Air is released to the atmosphere normally.

*3: The range is -5 to 50°C when a digital pressure sensor is used.

How to order

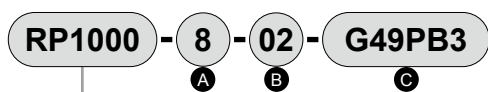

Model
RP1000: Precision regulator

A Port size		B Set pressure range		C Other attachments	
8	Rc1/4	02	MAX.0.2 MPa	Blank	Without attachment
		04	MAX.0.4 MPa	G49P	Pressure gauge (G49D-6-□)
		07	MAX.0.7 MPa	B3	L type bracket
				R2	Digital pressure sensor

*1: A pressure gauge, a digital pressure sensor and a bracket are enclosed.

*2: A pressure gauge with the same pressure range as the regulator is enclosed.

*3: One R1/8 plug is enclosed with the product.

Discrete attachment model No.

Model	Discrete attachment model No.
RP1000-8-02-G49P	G49D-6-P02
RP1000-8-04-G49P	G49D-6-P04
RP1000-8-07-G49P	G49D-6-P10
RP1000-8- ⁰² / ₀₄ -B3	B131
RP1000-8- ⁰² / ₀₄ -R2	PPX-R10N-6M

Clean-room specifications (Catalog No. CB-033SA)

● Anti-dust generation structure for use in cleanrooms

RP1000-.....- P70

Internal structure and parts list

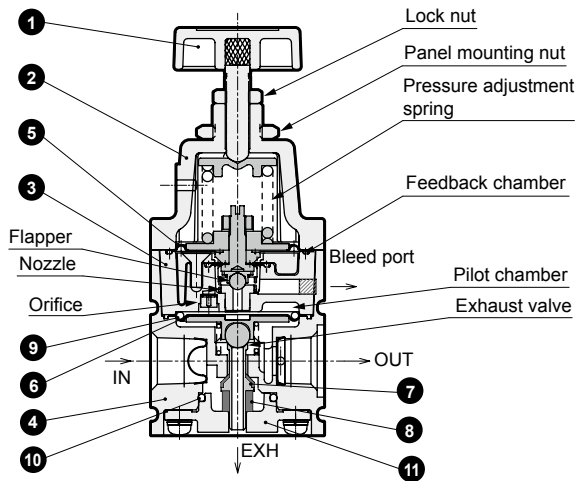

No.	Part name	Material
1	Pressure adjustment knob	Polyacetal resin, stainless steel
2	Cover	Aluminum alloy die-casting
3	Pilot body assembly	Aluminum alloy die-casting, etc.
4	Body	Aluminum alloy die-casting
5	Pilot diaphragm	Hydrogenated nitrile rubber
6	Main diaphragm	Hydrogenated nitrile rubber
7	Valve	Hydrogenated nitrile rubber, stainless steel
8	Bottom rubber	Silicone rubber
9	O-ring	Nitrile rubber
10	O-ring	Hydrogenated nitrile rubber
11	Bottom plug	Polybutylene terephthalate resin

Operational explanation

Air supplied from the IN side is prevented from flowing to the OUT side by the 7 valve. Some supplied air passes through the orifice to flow into the pilot chamber.

When the 1 pressure adjustment knob is rotated, the pressure adjustment spring is compressed, and the 5 pilot diaphragm and the flapper are pushed down to close the nozzle.

If the pressure in the pilot chamber rises, the 6 main diaphragm is forced lower to open the 7 valve, and to supply air to the OUT side. The intake air flows into the feedback chamber, and works on the 5 pilot diaphragm. If the diaphragm is forced upward until the air reaches the pressure of the regulator spring, the 5 pilot diaphragm and flapper are forced upward to open the nozzle, and an extremely small amount of air is released to the atmosphere to reduce pressure in the pilot chamber. At the same time, the OUT side pressure works on the 6 main diaphragm to force it upward, and the 7 valve is closed and the set pressure is maintained.

When the air is consumed and the pressure drops on the OUT side, the pressure in the feedback chamber also drops. The 5 pilot diaphragm and the flapper are forced lower to close the nozzle. This allows the pressure in the pilot chamber to decrease, and the 6 main diaphragm is forced upward to open the exhaust valve, and the surplus pressure is exhausted from EXH port in OUT side to the atmosphere.

This pilot pressure control method using the nozzle and flapper can follow up a minimal pressure change, which enables the high precision pressure control.

Repair parts list

For 0.2 and 0.4 MPa

Model No.	No.
RP1000-PILOT-ASSY	3, 5
RP1000-DIAPHRAGM-ASSY	6, 9
RP1000-VALVE-ASSY	7, 8, 10

For 0.7 MPa

Model No.	No.
RP1000-PILOT-ASSY-07	3, 5
RP1000-DIAPHRAGM-ASSY-07	6, 9
RP1000-VALVE-ASSY-07	7, 8, 10

Dimensions

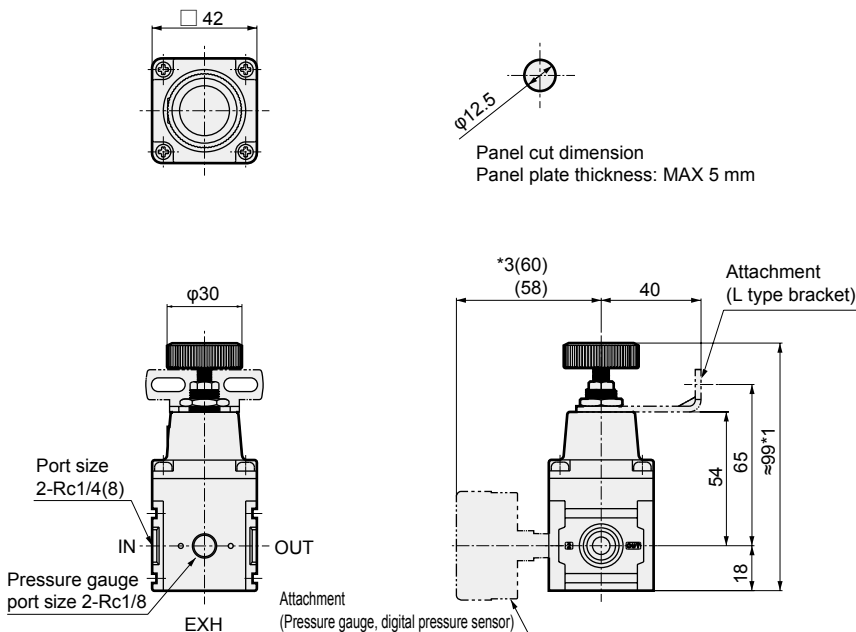

- *1: Dimensions at the setting pressure of 0 MPa
- *2: Pressure gauge, digital pressure sensor and bracket are optional.
- *3: Dimensions when the digital pressure sensor is assembled.

Pressure gauge

G49D-6 P02 P04 P10 Weight: 86g

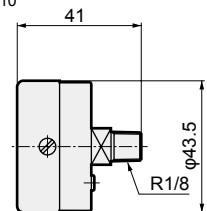

L type bracket B131

Weight: 29 g
Material: Steel Nickel plated

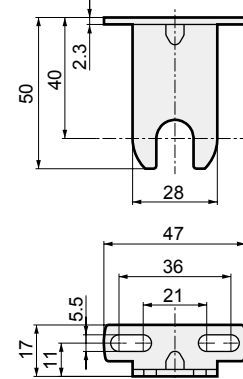

F.R.L
F (Filtr)
R (Reg)
L (Lub)
PresSW
Shutoff
SlowStart
FimResistFR
Oil-ProhR
MedPresFR
No Cu/ PTFE FRL
Outdrs FR
F.R.L (Related)
CompFRL
LgFRL
PrecsR
VacF/R
Clean FR
ElecPneuR
AirBoost
SpdContr
Silncr
CheckV/ other
Jnt/tube
AirUnt
PrecsCompn
Mech/ ElecPresSw
ContactSW
AirSens
PresSW Cool
AirFloSens/ Contr
WaterRISens
TotAirSys (Total Air)
TotAirSys (Gamma)
RefrDry
DesicDry
HiPolymDry
MainFiltr
Dischrg etc
Ending

RP1000 Series

F.R.L Dimensions

● PPX-R10N-6M

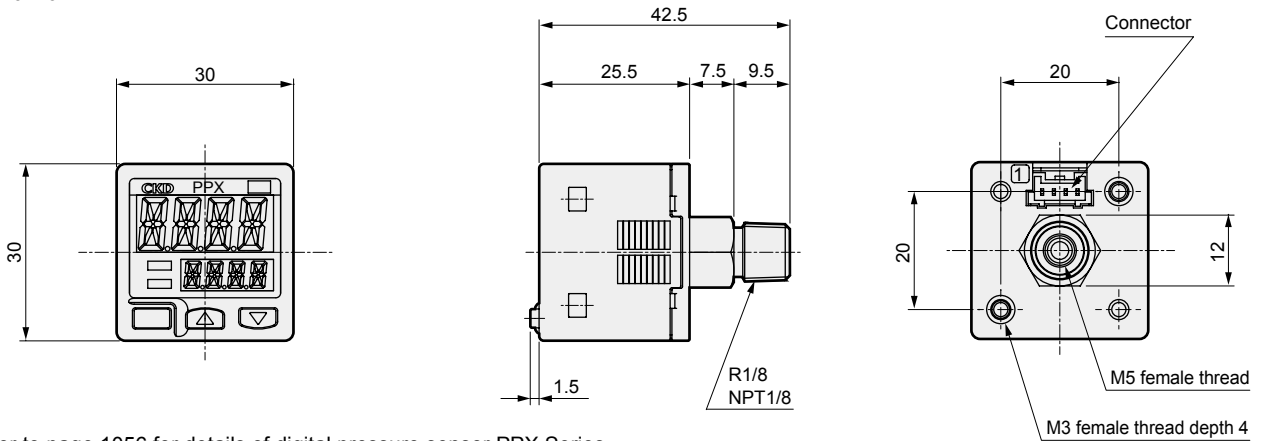

Note: Refer to page 1056 for details of digital pressure sensor PPX Series.

Weight: 40g

Flow characteristics

● RP1000-8-07

● RP1000-8-04

● RP1000-8-02

● RP1000-8-02

(Flow characteristics at low pressure)

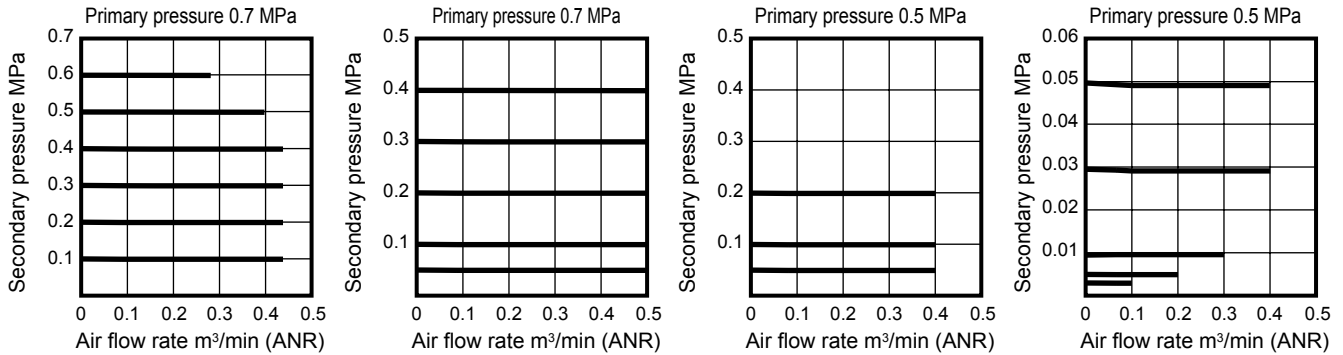

Relief flow characteristics

● RP1000-8-07

● RP1000-8-04

● RP1000-8-02

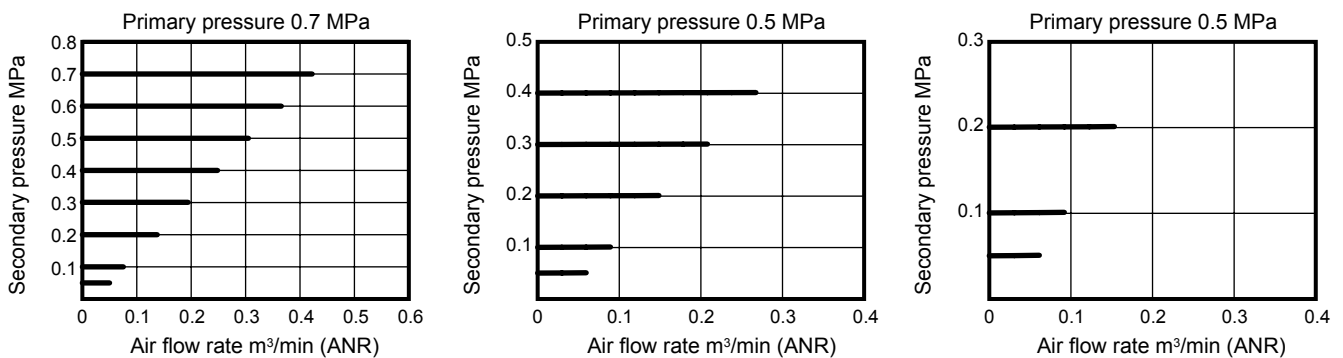

Pressure characteristics

● RP1000-8-07

● RP1000-8-04

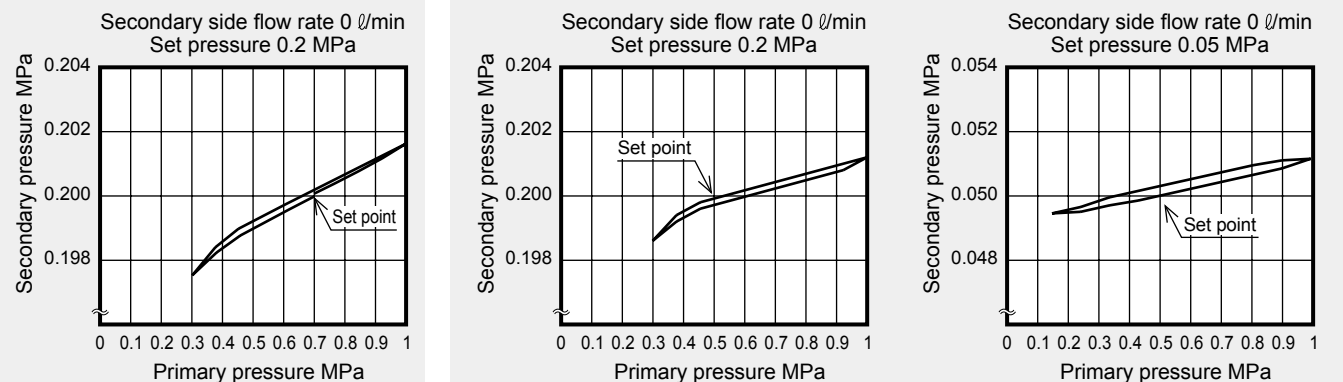

Pressure characteristics

● RP1000-8-02

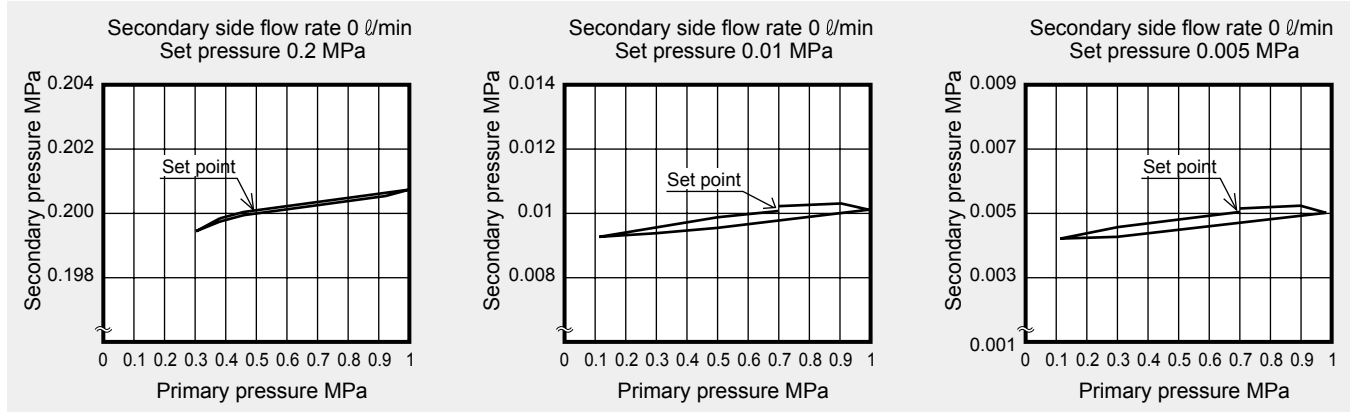

Cylinder speed range of RP1000

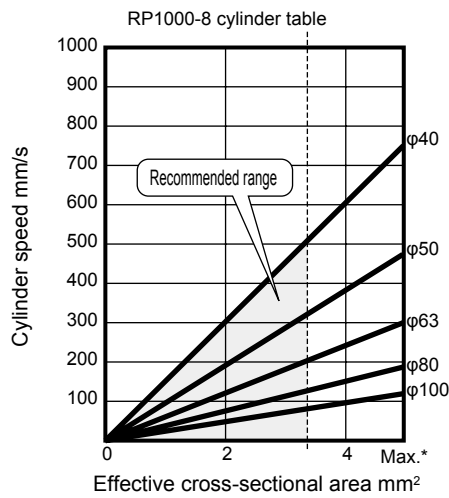

This cylinder table shows the available range according to the air supply and exhaust flow rate of the precision regulator and the required consumption flow rate at the cylinder PUSH/PULL.

----- Recommended cylinder line
(70% of max. flow rate is recommended)

* Max. cylinder line
(Cylinder directly installed)

Note: Using at a speed higher than the maximum could cause relief malfunctions.

Example of precise pressure control system

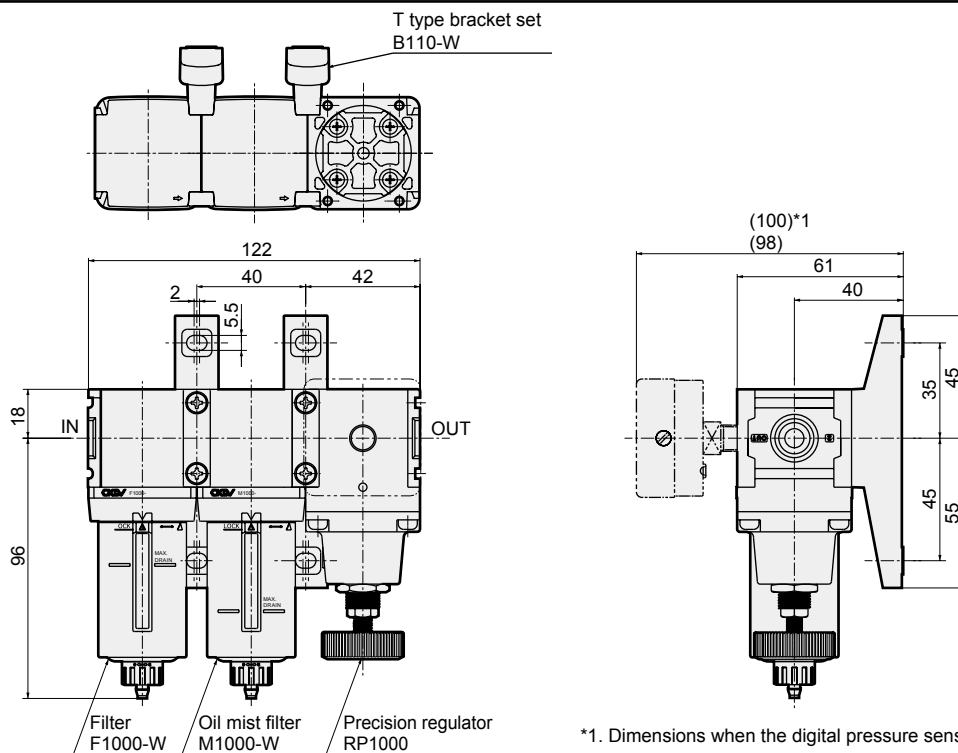

* Contact CKD if required for assembly.

Compatible model	Filter	Oil mist filter	Precision regulator	T type bracket set
Product model No.	F1000-W	M1000-W	RP1000	B110-W (2 pcs.)

- F.R.L
- F (Filtr)
- R (Reg)
- L (Lub)
- PresSW
- Shutoff
- SlowStart
- FimResistFR
- Oil-ProhR
- MedPresFR
- No Cu/
PTFE FRL
- Outdrs FR
- F.R.L
(Related)
- CompFRL
- LgFRL
- PrecsR**
- VacF/R
- Clean FR
- ElecPneuR
- AirBoost
- SpdContr
- Silncr
- CheckV/
other
- Jnt/tube
- AirUnt
- PrecsCompn
- Mech/
ElecPresSw
- ContactSW
- AirSens
- PresSW
Cool
- AirFloSens/
Contr
- WaterRtSens
- TotAirSys
(Total Air)
- TotAirSys
(Gamma)
- RefrDry
- DesicDry
- HiPolymDry
- MainFiltr
- Dischrg
etc
- Ending



Precision regulator RP2000 Series

● Port size: Rc1/4 Rc3/8

JIS symbol



Specifications

Descriptions	RP2000-8-08	RP2000-10-08
Working fluid	Compressed clean air (refer to recommended air circuit on page 453)	
Max. working pressure	MPa	1.0 (≈150 psi, 10 bar)
Min. working pressure	MPa	Set pressure +0.1 (≈15 psi, 1 bar) *1
Proof pressure	MPa	1.5 (≈220 psi, 15 bar)
Ambient / fluid temperatures	°C	-5 (23°F) to 60 (140°F) (no freezing) *3
Set pressure	MPa	0.03 (≈4.4 psi, 0.3 bar) to 0.85 (≈120 psi, 8.5 bar)
Sensitivity		Within 0.2% of full scale
Repeatability		Within ±0.5% of full scale
Air consumption	ℓ/min(ANR)	5 or less *2
Port size	Rc1/4	Rc3/8
Exhaust side port size		Rc3/8
Pressure gauge port size		Rc1/8
Weight	g	470

*1: Flow rate of the secondary side is to be zero.

*2: Conditions where the primary pressure is 0.7 MPa and set pressure is 0.3 MPa. Consumed air is normally released to the atmosphere from the bleed port and EXH port. So, air consumption is the total of consumption volume released from the bleed port and EXH port. Air 1 ℓ/min. (ANR) or less is released from EXH port.

*3: The range is -5 to 50°C when a digital pressure sensor is used.

How to order

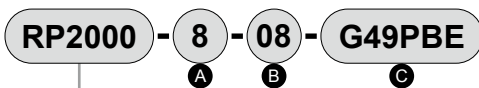

Model
RP2000: Precision regulator

A Port size		B Set pressure range		C Other attachments	
8	Rc1/4	08	MAX.0.85 MPa	Blank	Without attachment
10	Rc3/8			G49P	Pressure gauge
				B	C type bracket
				E	Silencer
				R2	Digital pressure sensor

*1: If an Rc1/2 port size is required, use a pipe adaptor set (model No.: A400-15-W).

*2: Attachment is attached.

*3: The pipe adaptor set and C type bracket cannot be used together.

*4: One R1/8 plug is enclosed with the product.

Discrete attachment model No.

Attachment code	Discrete attachment model No.
G49P	G49D-6-P10
B	B220
E	SLW-10A
R2	PPX-R10N-6M

Clean-room specifications (Catalog No. CB-033SA)

● Anti-dust generation structure for use in cleanrooms

RP2000 - - P70

Specifications for rechargeable battery (Catalog No. CC-1226A)

● Structure compatible with rechargeable battery manufacturing process

RP2000-..... - P4*

Internal structure and parts list

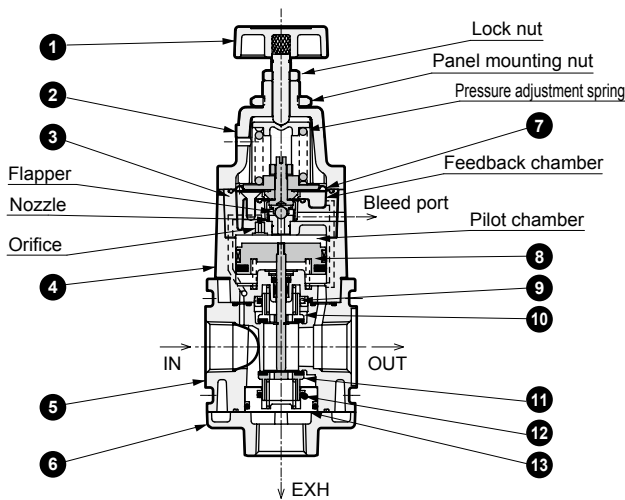

No.	Part name	Material
1	Pressure adjustment knob	Polyacetal resin, stainless steel
2	Cover	Aluminum alloy die-casting
3	Pilot body assembly	Aluminum alloy die-casting, etc.
4	Top body assembly	Aluminum alloy die-casting, etc.
5	Body	Aluminum alloy die-casting
6	Exhaust adaptor	Aluminum alloy die-casting
7	Pilot diaphragm	Hydrogenated nitrile rubber
8	Piston assembly	Aluminum, stainless steel, etc.
9	O-ring	Nitrile rubber
10	Exhaust valve	Copper alloy, hydrogenated nitrile rubber
11	Air supply valve	Copper alloy, hydrogenated nitrile rubber
12	O-ring	Nitrile rubber
13	Bottom cap	Copper alloy

Operational explanation

Air supplied from IN side is stopped its flow to OUT side by the air supply valve. Some supplied air passes through the orifice to flow into the pilot chamber. When the ① pressure adjustment knob is rotated, the pressure adjustment spring is compressed, and the ⑦ pilot diaphragm and the flapper are pushed down to close the nozzle. Pressure in the pilot chamber rises, forcing the piston lower to open the ④ air supply valve, and to supply air to OUT side. The intake air flows into the feedback chamber, and works on the ⑦ pilot diaphragm. If the diaphragm is forced upward until the air reaches the pressure of the regulator spring, the ⑦ pilot diaphragm and flapper are forced upward to open the nozzle, and an extremely small amount of air is released to the atmosphere to reduce pressure in the pilot chamber. At the same time, the OUT side pressure works on the piston to force it upward, the ⑪ air supply valve is closed and the set pressure is maintained.

When the air is consumed and the pressure drops on the OUT side, the pressure in the feedback chamber also drops. The ⑦ pilot diaphragm and the flapper are forced lower to close the nozzle. Pressure in the pilot chamber rises, causing the piston to open the ④ air supply valve, compensating for any drop in pressure. If the OUT side pressure increases further than the set pressure, the pressure in the feedback chamber also increases. The ⑦ pilot diaphragm and the flapper are forced upward to open the nozzle. This allows the pressure in the pilot chamber to decrease, and the piston is forced upward to open the ⑩ exhaust valve; the surplus pressure is pumped from EXH port on the OUT side to the atmosphere. This pilot pressure control method using the nozzle and flapper can follow up a minimal pressure change, which enables the high precision pressure control.

Repair parts list

No.	Part name	Model No.
3	Pilot body assembly	RP2000-PILOT-ASSY
7	Pilot diaphragm	
4	Top body assembly	RP2000-TOP-BODY-ASSY
11	Air supply valve	RP2000-BTM-VALVE-ASSY
12	O-ring	
13	Bottom cap	

Note: Parts No. (8), (9), (10) are contained in the top body assembly (4)

Dimensions

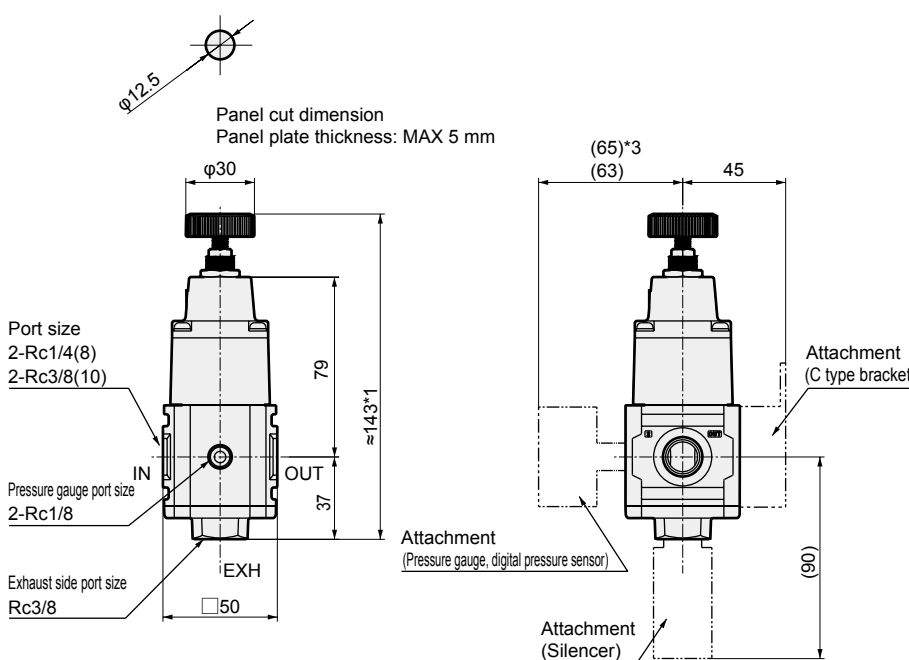

*1: Dimensions at the setting pressure of 0 MPa

*2: Pressure gauge, digital pressure sensor, C type bracket and silencer are optionally included.

*3: Dimensions when the digital pressure sensor is assembled.

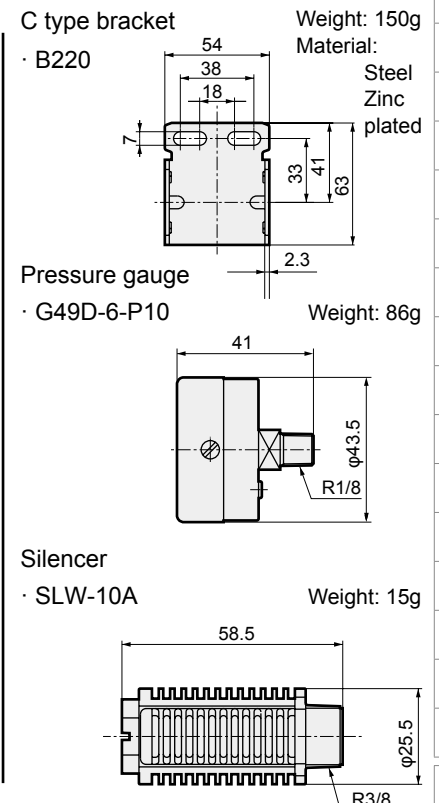

- F.R.L
- F (Filtr)
- R (Reg)
- L (Lub)
- PresSW
- Shutoff
- SlowStart
- FimResistFR
- Oil-ProhR
- MedPresFR
- No Cu/ PTFE FRL
- Outdrs FR
- F.R.L (Related)
- CompFRL
- LgFRL
- PrecsR
- VacF/R
- Clean FR
- ElecPneuR
- AirBoost
- SpdContr
- Silncr
- CheckV/ other
- Jnt/tube
- AirUnt
- PrecsCompn
- Mech/ ElecPresSw
- ContactSW
- AirSens
- PresSW Cool
- AirFloSens/ Contr
- WaterRISens
- TotAirSys (Total Air)
- TotAirSys (Gamma)
- RefrDry
- DesicDry
- HiPolymDry
- MainFiltr
- Dischrg etc
- Ending

RP2000 Series

F.R.L Dimensions

F (Filtr) ● PPX-R10N-6M

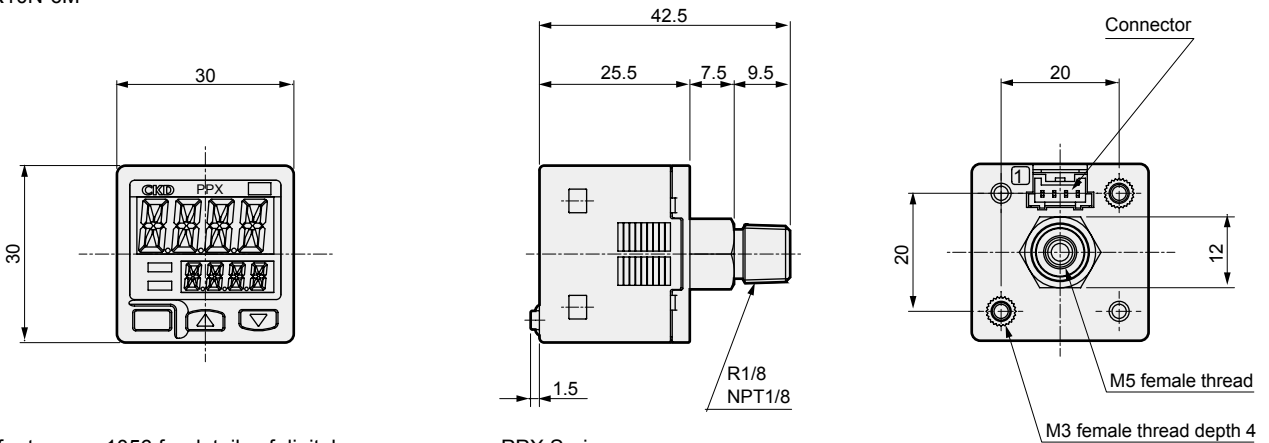

Note: Refer to page 1056 for details of digital pressure sensor PPX Series.

Weight: 40g

Flow characteristics

● RP2000-10-08

Primary pressure 0.7 MPa

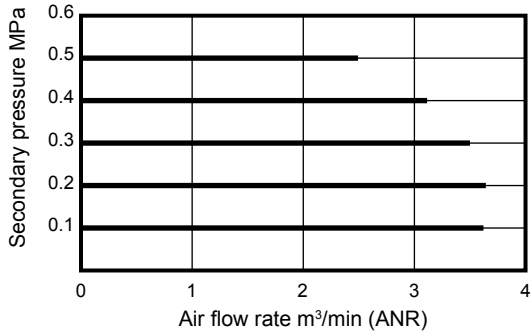

● RP2000-8-08

Primary pressure 0.7 MPa

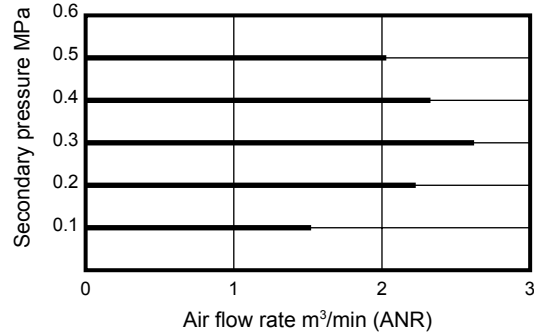

Relief flow characteristics

● RP2000-10-08

Primary pressure 0.7 MPa

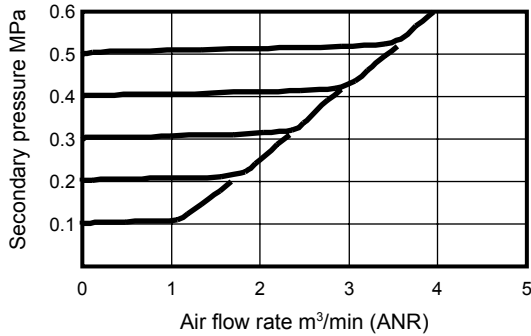

● RP2000-8-08

Primary pressure 0.7 MPa

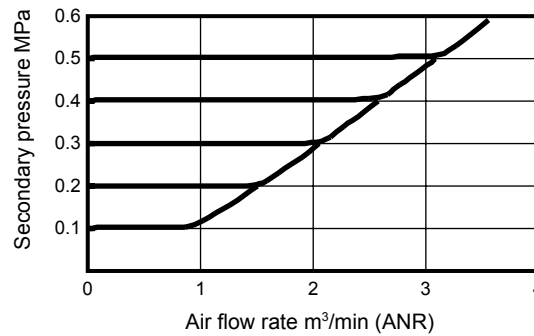

Pressure characteristics

● RP2000-*-08

Secondary side flow rate 0 l/min

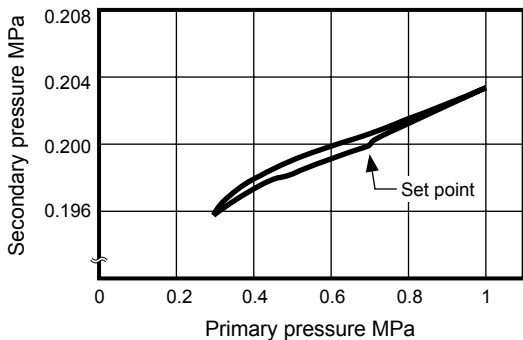

Cylinder speed range of RP2000

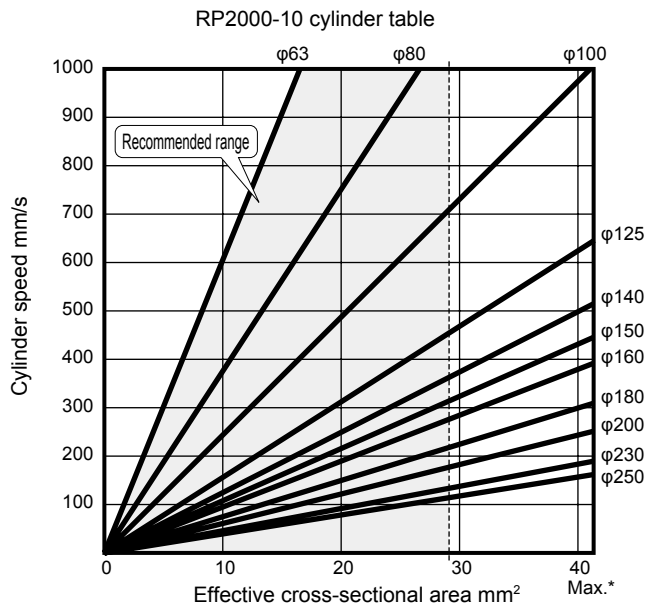

This cylinder table shows the available range according to the air supply and exhaust flow rate of the precision regulator and the required consumption flow rate at the cylinder PUSH/PULL.

----- Recommended cylinder line
(70% of max. flow rate is recommended)

* Max. cylinder line
(Cylinder directly installed)

Example of precise pressure control system

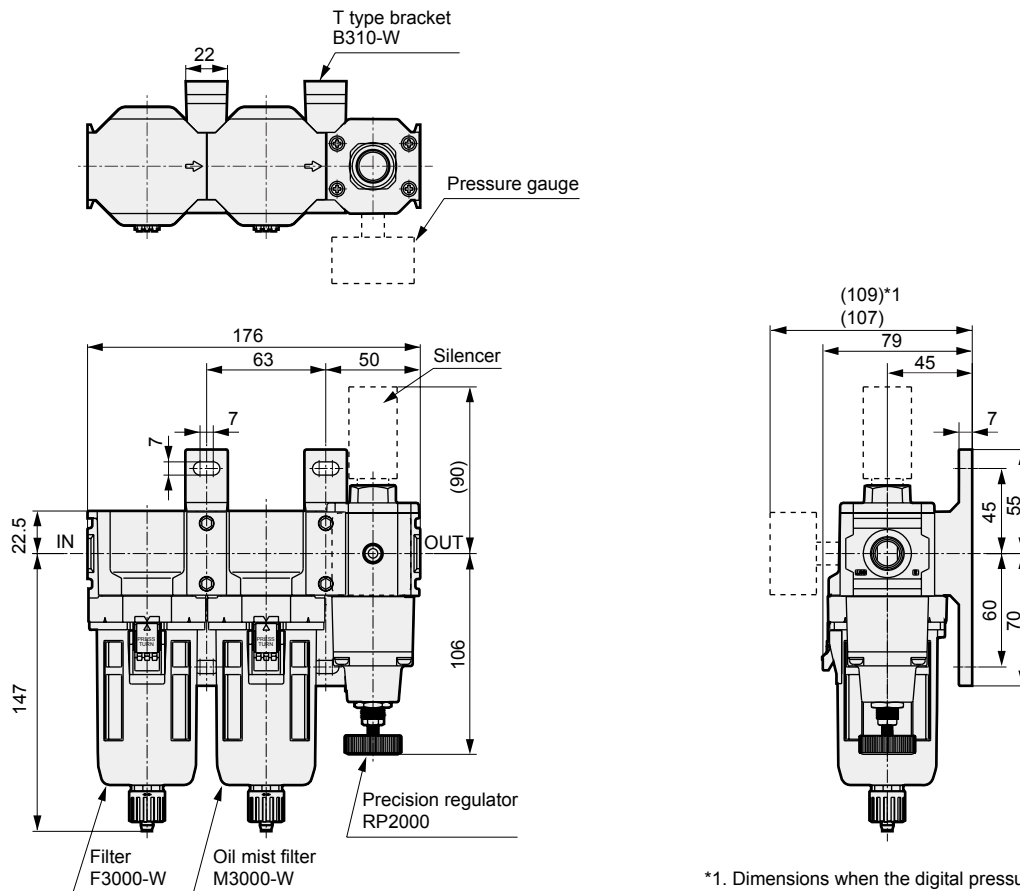

*1. Dimensions when the digital pressure sensor is assembled.

* Contact CKD if required for assembly.

Compatible model	Filter	Oil mist filter	Precision regulator	T type bracket set
Product model No.	F3000-W	M3000-W	RP2000	B310-W (2 pcs.)

- F.R.L
- F (Filtr)
- R (Reg)
- L (Lub)
- PresSW
- Shutoff
- SlowStart
- FimResistFR
- Oil-ProhR
- MedPresFR
- No Cu/ PTFE FRL
- Outdrs FR
- F.R.L (Related)
- CompFRL
- LgFRL
- PrecsR**
- VacF/R
- Clean FR
- ElecPneuR
- AirBoost
- SpdContr
- Silncr
- CheckV/ other
- Jnt/tube
- AirUnt
- PrecsCompn
- Mech/ ElecPresSw
- ContactSW
- AirSens
- PresSW Cool
- AirFloSens/ Contr
- WaterRtSens
- TotAirSys (Total Air)
- TotAirSys (Gamma)
- RefrDry
- DesicDry
- HiPolymDry
- MainFiltr
- Dischrg etc
- Ending

Applications

Fluid discharge control

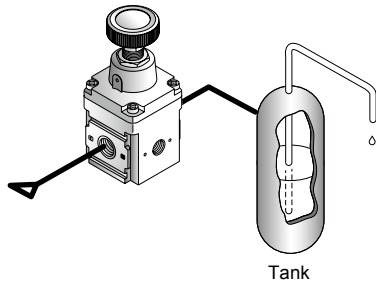

Balance

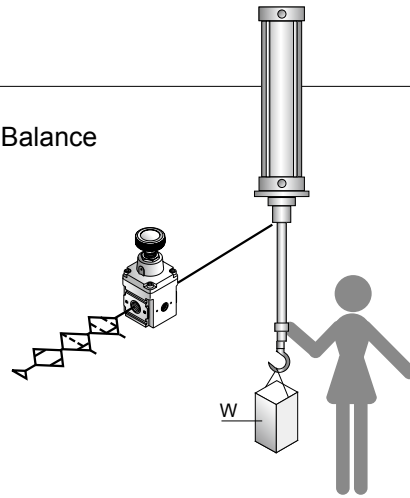

Pilot pressure control

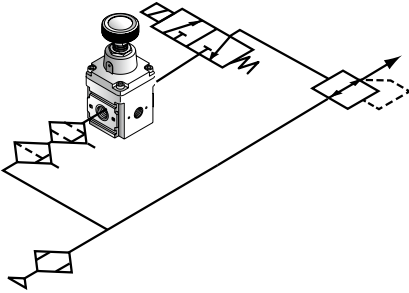

Very low pressure blow

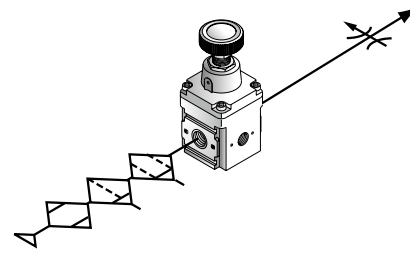

Quick pressure regulation of tank pressure

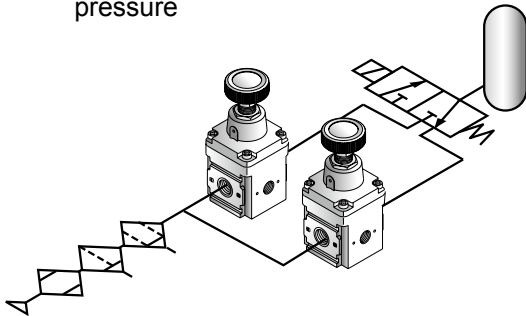

Leakage test

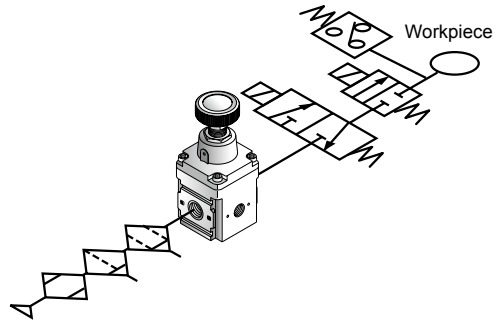

Tension control

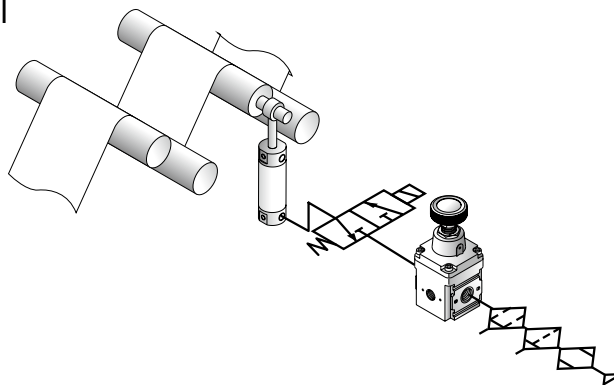

- F.R.L
- F (Filtr)
- R (Reg)
- L (Lub)
- PresSW
- Shutoff
- SlowStart
- FimResistFR
- Oil-ProhR
- MedPresFR
- No Cu/
PTFE FRL
- Outdrs FR
- F.R.L
(Related)
- CompFRL
- LgFRL
- PrecsR**
- VacF/R
- Clean FR
- ElecPneuR
- AirBoost
- SpdContr
- Silncr
- CheckV/
other
- Jnt/tube
- AirUnt
- PrecsCompn
- Mech/
ElecPresSw
- ContactSW
- AirSens
- PresSW
Cool
- AirFloSens/
Contr
- WaterRtSens
- TotAirSys
(Total Air)
- TotAirSys
(Gamma)
- RefrDry
- DesicDry
- HiPolymDry
- MainFiltr
- Dischrg
etc
- Ending